

fTool INTERNATIONAL

F-Tool MultiClamp

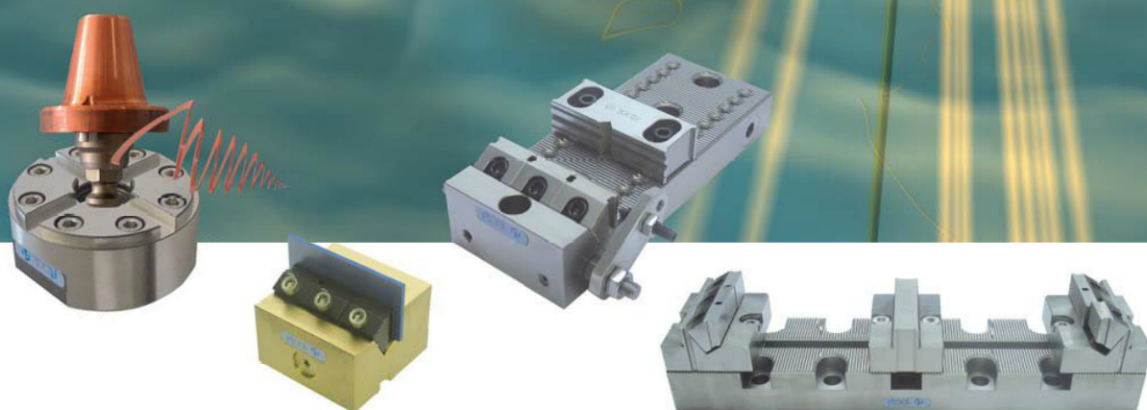

F-Tool MultiClamp

Universal, simple, conclusive

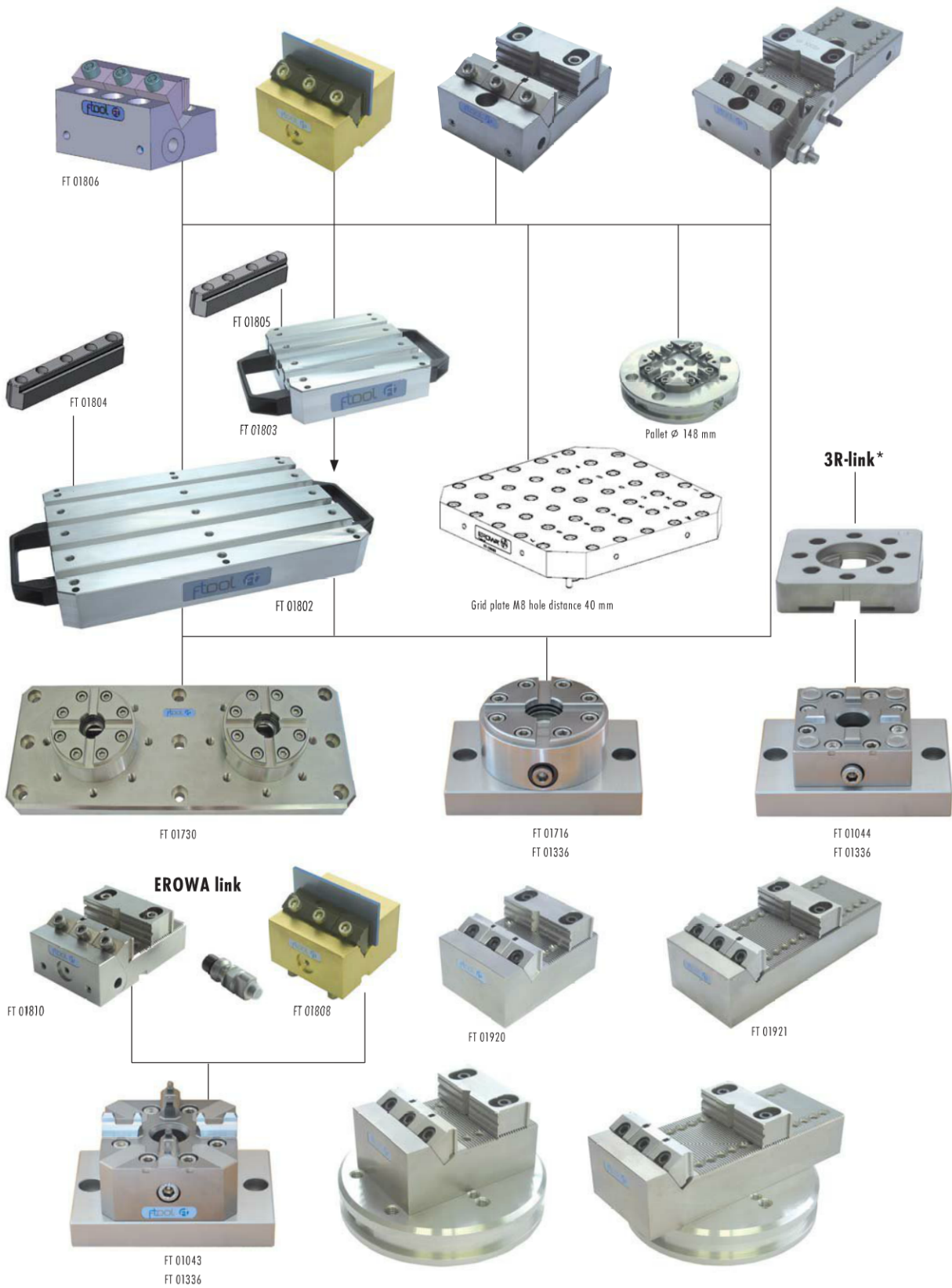

F-Tool MultiClamp

From the electrode holder to the PIN tooling system - a system with a great clamping potential

A simple solution for clamping and positioning

The PIN tooling system provides:

- accurate and extensive clamping possibilities
- economic and extendable solutions

The F-Tool PIN ZeroPoint centering system is suitable for multi-functional clamping tasks.

PIN center chuck



PIN system applications



F-Tool pull-down vises



PIN ZeroPoint centering system



PIN tooling system

F-Tool has created a simple, economical solution to a whole range of clamping problems, for clamping work pieces quickly, powerfully and precisely in a defined position. One side is milled and fitted with two drilling screws. One drill composes the center in combination with the centering bolt. The other composes of the angle position together with the index screw. Now the piece is accessible on 5 sides and can be clamped in the center chuck and worked on with 4 x 90° reference accuracy. The Z-reference forms the work piece support surface.

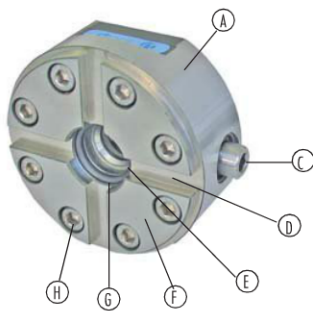

- A = PIN center chuck
- B = PIN centering bolt
- C = Clamping screw
- D = Cross centering slot
- E = Centering drill
- F = Support Z
- G = Sealing ring
- H = Fixing screw 8 x M6 TK 61
- I = flexible centering plate
- K = Clamping mechanism
- L = Locating pin \varnothing 4 mm

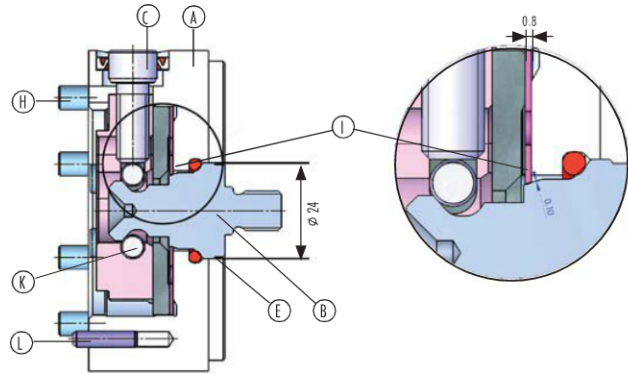

Single palletizing

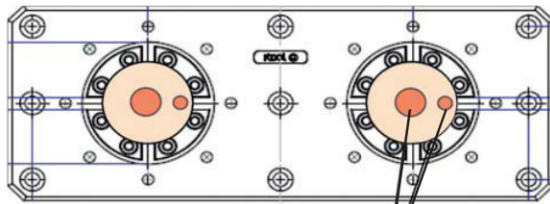

PIN reference position and PIN index

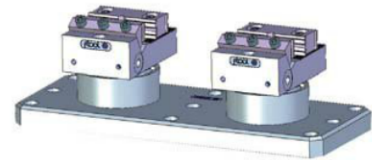

Multiple palletizing

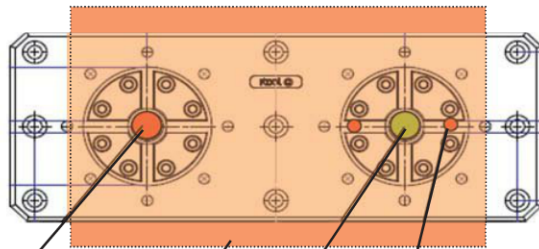

PIN reference position with RefPIN centering bolt FT 01721 Pallet FT 01802 PIN clamp only with the ClampPIN FT 01722 PIN index for the angle position FT 01722

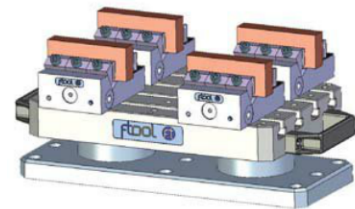

A simple, modular, economic and conclusive system!

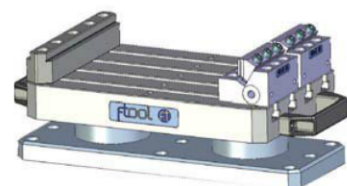
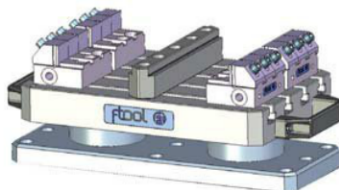
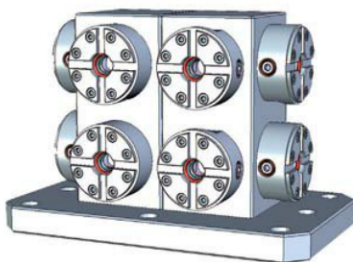
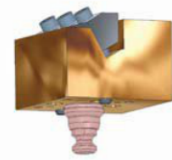
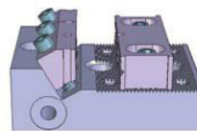
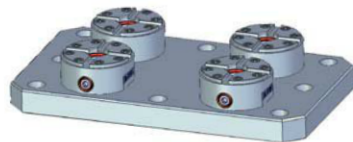

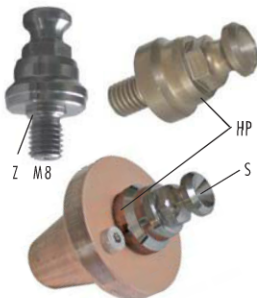
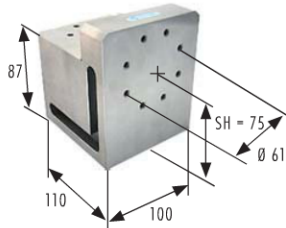
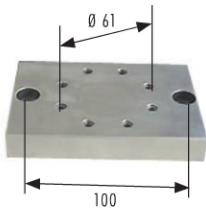
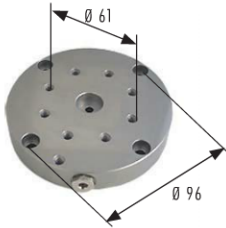

F-Tool PIN center chuck

The PIN center chuck is a compact reference system and is able for the collet of electrodes and work pieces. It's also the base of the F-Tool PIN ZeroPoint centering system. The centering, respective the positioning happens in two steps. The first step is the pre-centering with the PIN centering bolt. The precise centering is done, if the cone of the spigot is intervening on the flexible centering plate, and the piece is drawn to the clamping area. With the intervention of the PIN index 8 mm into the cross slot, the angle coat is defined.

Article no.	Article	Quantity	Weight	Code
FT 01716	FTool PIN center chuck	1 piece	1.48 kg	P
FT 01717	FTool PIN center chuck with nonius graduation	1 piece	1.54 kg	P

EDM adapter plate

Parallel ground, corrosion-resistant adapter plate for EDM quills. With flushing connection and M6 thread for power cable.

Dimension: $\varnothing 110 \times 18$ mm Hole pattern for chuck: 8 x M6 TK $\varnothing 61 \times 45^\circ$
 Hole pattern for quill: 4 x 6.5 TK $\varnothing 96 \times 90^\circ$

Article no.	Article	Quantity	Weight	Code
FT 01236	EDM adapter plate $\varnothing 100$ mm chuck 80/PIN chuck	1 piece	1.32 kg	A
FT 01829	EDM adapter plate $\varnothing 110$ mm without hole pattern $\varnothing 96$ mm	1 piece	1.32 kg	A

→ Delivered with screws and flushing seal

Adapter plate

Parallel ground, corrosion-resistant adapter plate, suited for machine tool tables.

Dimension: 120 x 82 x 18 mm
 Hole pattern collet chuck: 8 x M6 TK $\varnothing 61 \times 45^\circ$
 Collet machine tool table: with brackets or 2 x M8 distance 100 mm

Article no.	Article	Quantity	Weight	Code
FT 01336	Adapter plate 120 x 82 mm chuck 80/PIN chuck	1 piece	1.40 kg	A

Square block

Accurate ground square block, corrosion-resistant, for the assembling of one or two ER chuck 80P (FT 01043), chuck 80 IF3R (FT 01044) or PIN center chuck (FT 01716) in vertical or horizontal position.

For the application with brackets on diverse tooling machines.
 Spindle height at horizontal installation of the chuck: 75 mm

Article no.	Article	Quantity	Weight	Code
FT 01483	Square block chuck 80/PIN chuck	1 piece	8.20 kg	A

F-Tool PIN center chuck IF EROWA

With the PIN center chuck EROWA the electrodes and work pieces can be inserted into the EROWA ITS system.

Article no.	Article	Quantity	Weight	Code
FT 01728	FTool PIN center chuck IF EROWA	1 piece	1.86 kg	P

→ Delivered with chucking spigot F/A EDM automatic with flushing

F-Tool PIN center chuck IF3R

With the PIN center chuck 3R the electrodes and work pieces can be inserted into the 3R system.

Article no.	Article	Quantity	Weight	Code
FT 01729	FTool PIN center chuck IF3R	1 piece	1.60 kg	P

→ Delivered without chucking spigot

F-Tool PIN centering bolt

According to the application, the suitable centering bolts may be inserted.

HP = PIN centering bolt high precision / ground
 Z = with centering bundle
 S = flushing hole

Article no.	Article	Quantity	Weight	Code
FT 01719	FTool RefPIN HP-Z with flushing S (grinded)	1 piece	0.07 kg	P
FT 01720	FTool RefPIN-Z with flushing S	Set of 10 pieces	0.58 kg	P
FT 01721	FTool RefPIN-Z without flushing S	Set of 10 pieces	0.60 kg	P
FT 01722	FTool RefPIN without bundle Z	Set of 10 pieces	0.60 kg	P
FT 01723	FTool ClampPIN (without bundle Z and without centering)	Set of 10 pieces	0.53 kg	P

F-Tool PIN holder system

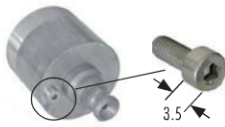

F-Tool PIN index 8 mm M5

The orientation coat can be defined with the PIN index.

Article no.	Article	Quantity	Weight	Code
FT 01724	FTool PIN index Ø 8/3.5 mm M5 A2 (for electrodes)	Set of 10 pieces	0.01 kg	P



F-Tool PIN clamping holder

The PIN clamping holder is a basic holder made in aluminium for the collet of electrodes and work pieces.

Article no.	Article	Quantity	Weight	Code
FT 01725	FTool PIN clamping holder 26 mm	1 piece	0.62 kg	P

Others sizes on request.

→ Delivered incl. assembled PIN index, without centering bolt



F-Tool PIN electrode spanner

The PIN electrode spanner made in aluminium is very good qualified for an economic collet of electrode blanks and the conditioning in the PIN system.

Article no.	Article	Quantity	Weight	Code
FT 01726	FTool PIN electrode spanner Ø 16 mm	Set of 10 pieces	1.80 kg	P

Others diameters on request.

→ Delivered incl. assembled PIN index, without centering bolt



F-Tool copper blank

The copper blank is assembled with a PIN index and prepared for the centering bolt.

Article no.	Article	Quantity	Weight	Code
FT 01234	FTool copper blank Ø 50 x L = 45 mm prepared for PIN adapter	Set of 10 pieces	7.66 kg	E

Others sizes on request.

→ Delivered incl. assembled PIN index, without centering bolt



F-Tool PIN pallet aluminium

The PIN pallet aluminium is an economic, universal pallet, applicable for the collet of electrodes and work pieces.

Article no.	Article	Quantity	Weight	Code
FT 01727	FTool PIN pallet alu Ø 80 mm	1 piece	0.34 kg	P

→ Delivered incl. assembled PIN index, without centering bolt



Interface plate

Interface plate 146 x 56 mm with hole pattern for accommodating:

Visc 80VL50 (FT 01320) & magnetic table 140 x 50 x 44 mm (FT 01326)

The rear side is compatible with RefPIN set (FT 01815) / adapter plate ER und 3R with hole grid 40 mm

Article no.	Article	Quantity	Weight	Code
FT 01817	FTool interface plate 146 x 56 mm for FT 01326 and FT 01321	1 piece	0.88 kg	P



F-Tool clamping unit

Spare part for F-Tool PIN center chuck FT 01716 and FT 01717.

Article no.	Article	Quantity	Weight	Code
FT 02010	FTool clamping unit (for FT 01716)	1 piece	0.12 kg	C

F-Tool turn and index table

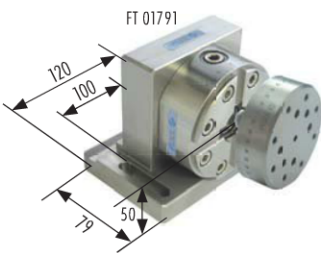

F-Tool WEDM square block-index-table

The F-Tool center chuck with spring-steel centering, 90° raster-indexation or stageless indexation with graduation. Able for the direct application on the drilling machine, on the WEDM-machine table with hole pattern 50 mm or to clamp with the F-Tool basic rulers (arbour height 50 mm). Delivered with a universal index adapter plate 80 with graduation (FT 01792) to adapt the ER chuck 80P (FT 01043), chuck 80 IF3R (FT 01044), collet chuck holder (FT 01580/FT 01581), electrodes or working pieces.

Dimension: 120 x 79 x 92 mm / Spindle height 50 mm

Article no.	Article	Quantity	Weight	Code
FT 01791	FTool WEDM square block-index-table 80, corrosion-resistant	1 piece	2.50 kg	W



F-Tool universal index adapter plate

Universal adapter plate 80 with nonius-display to adapt the ER chuck 80P (FT 01043), chuck 80 IF3R (FT 01044), collet chuck holder (FT 01580/FT 01581), electrodes or working pieces.

Hole pattern: 8 x M8 reference circle 61 for ER chuck 80P & chuck 80 IF3R

For 6 x M6 circle diameter 40 mm (to adapt collet chuck holder, front spanner FT 01572 or electrodes respective working pieces)

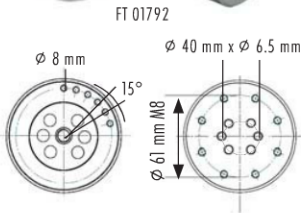

Article no.	Article	Quantity	Weight	Code
FT 01792	FTool universal index adapter plate 80 with graduation, corrosion-resistant	1 piece	0.90 kg	W
FT 01430	FTool PIN index Ø 8/7 mm M5, corrosion-resistant	1 piece	0.01 kg	P
FT 01745	FTool PIN index Ø 8/7 mm M5, corrosion-resistant, hardened & ground	1 piece	0.01 kg	P

→ Delivered with RefPIN HP Z (FT 01719) and PIN index (FT 01430)



F-Tool collet chuck holder

Collet chuck holder with clamping nut for collet chucks ETS 32.

The collet chuck holder is corrosion-resistant and under careful care he could be also inserted in the water.

Article no.	Article	Quantity	Weight	Code
FT 01793	Collet chuck holder ETS32 incl. index adapter plate 80	1 piece	1.40 kg	W
FT 01581	FTool collet chuck holder ETS32 without adapter plate (corrosion-resist.)	1 piece	0.45 kg	A



Rustless, precision three-jawed chuck

Suitable for the application on EDM wire cutting machines under water. Hardened clamping jaws for the clamping of outside diameter Ø 1 - Ø 60 mm and inside diameter of Ø 12 - Ø 66 mm. Hole pattern 4 x M6, reference circle 40 mm. Clamping accuracy ± 0.01 mm, maximum work piece weight: 2 kg

Article no.	Article	Quantity	Weight	Code
FT 02008	3 Jaw scroll chuck DBF63 rustless 0-56 mm Ø 70 mm L = 40 mm	1 piece	0.76 kg	P

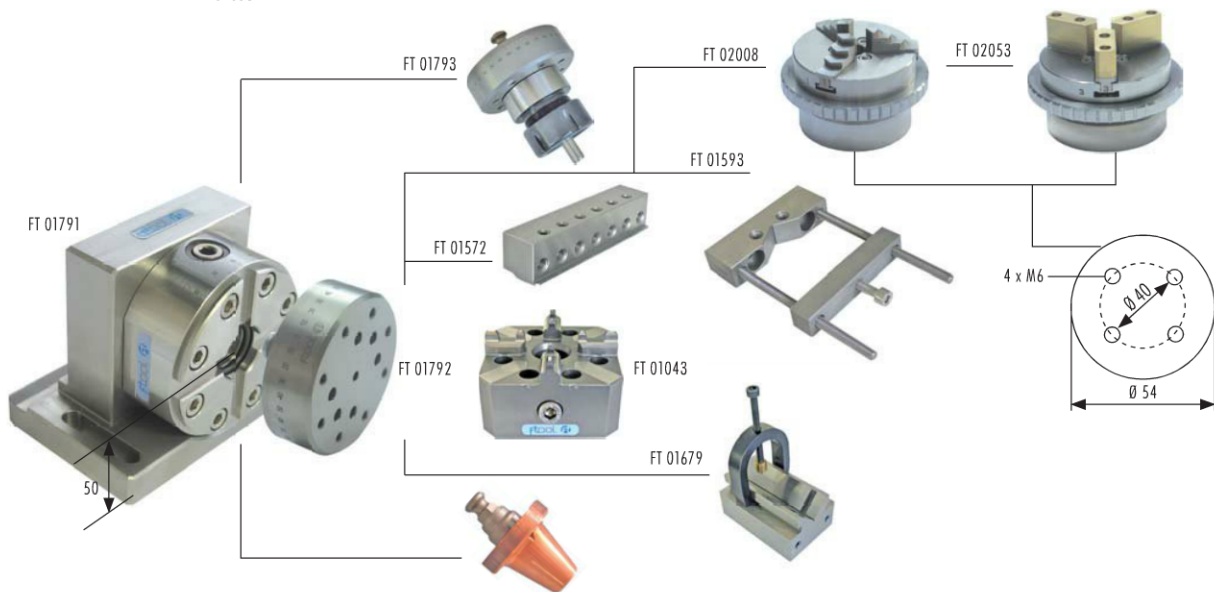

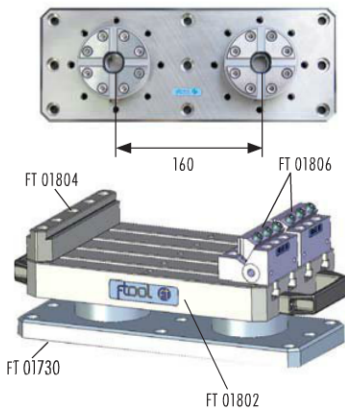

F-Tool PIN ZeroPoint centering system

PIN ZeroPoint centering system with two manual PIN center chucks = MB160.

The PIN ZeroPoint centering system is qualified for the single and multiple palletization. The precision of the system is <0.01 mm. Corrosion-resistant.

The chucks can be assembled individually or bridged with a pallet.

Artikel-Nr.	Artikel	Menge	Gewicht	Code
FT 01730	FTool PIN ZeroPoint centering system MB160	1 piece	8.54 kg	P
FT 01802	PIN T-slot pallet B160/280 x 180 x 37.5 mm	1 piece	4.50 kg	P
FT 01804	Stopper beam B180 H25 mm for pallet FT 01802, corrosion-resistant	1 piece	1.20 Kg	P
FT 01806	PIN clamping block 58 x 72 mm complete, corrosion-resistant	1 piece	1.06 kg	P

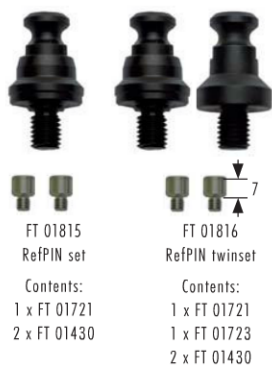

F-Tool PIN centering bolt set

For the pallets, we advise that you use the following centering bolt sets:

PIN set for single palletization

PIN twinset for the multiple palletization (1 centering bolt for the centering and 1 for clamping, plus 2 PIN index 8/7 mm M5 for the adjustment).

Article no.	Article	Quantity	Weight	Code
FT 01815	FTool RefPIN set	1 set	0.07 kg	P
FT 01816	FTool RefPIN twinset	1 set	0.16 kg	P
FT 01721	FTool RefPIN-Z without flushing	Set of 10 pieces	0.60 kg	P
FT 01722	FTool RefPIN without bundle	Set of 10 pieces	0.60 kg	P
FT 01723	FTool ClampPIN (without bundle and without centering)	Set of 10 pieces	0.53 kg	P
FT 01430	FTool PIN index Ø 8/7 mm M5, corrosion-resistant	1 piece	0.01 kg	P
FT 01745	FTool PIN index Ø 8/7 mm M5, corrosion-resistant, hardened & ground	1 piece	0.01 kg	P



F-Tool PIN T-slot pallet

PIN T-slot pallet in aluminium incl. handles. Interesting combinations can be created by combining with the F-Tool stopper beam FT 01804, clamping block FT 01806 and the range of F-Tool MultiClamps.

Article no.	Article	Quantity	Weight	Code
FT 01802	PIN T-slot pallet B160/280 x 180 x 37.5 mm	1 piece	4.50 kg	P
FT 01831	PIN universal pallet 280 x 180 x 30 mm	1 piece	4.92 kg	P

→ Delivered complete with RefPIN and PIN index



F-Tool PIN T-slot pallet

PIN T-slot pallet in aluminium incl. handles. Interesting combinations can be created by combining with the F-Tool stopper beam FT 01805, clamping block FT 01806 and the range of F-Tool MultiClamps.

Article no.	Article	Quantity	Weight	Code
FT 01803	PIN T-slot pallet 150 x 150 x 37.5 mm	1 piece	2.42 kg	P

→ Delivered complete with RefPIN and PIN index



F-Tool stopper beam

Stopper beam for T-slot pallet FT 01802 respective FT 01803 in combination with the clamping block FT 01806.

Article no.	Article	Quantity	Weight	Code
FT 01804	Stopper beam B180 H25 mm for pallet FT 01802, corrosion-resistant	1 piece	1.20 kg	P
FT 01805	Stopper beam B150 H25 mm for pallet FT 01803, corrosion-resistant	1 piece	1.00 kg	P

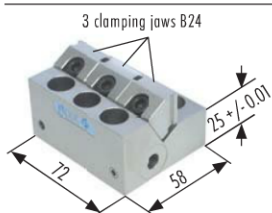

F-Tool clamping block

The F-Tool clamping socket consists of a pull-down clamping element with support, which can be flexibly inserted into the T-slot pallet together with opposing support stops. The QPQ-coated clamping elements are corrosion-resistant and can be inserted into coolant substances containing water. The clamping range of the flexible jaws is 3 mm. 1 clamping jaw B27 can be inserted in place of the 3 clamping jaws B24 mm.

Article no.	Article	Quantity	Weight	Code
FT 01806	PIN clamping block 58 x 72 mm complete, corrosion-resistant	1 piece	1.06 kg	P

→ Delivered incl. screws and T-slides

F-Tool MultiClamp

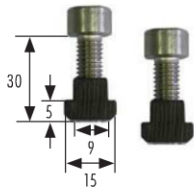

F-Tool PIN T-slot screw set

PIN T-slot screw set for PIN T-slot pallet.

Article no.	Article	Quantity	Weight	Code
FT 01818	FTool PIN T-slot screw set M8 x 30 mm, corrosion-resistant	Set of 2 pieces	0.06 kg	P

F-Tool clamping block B100

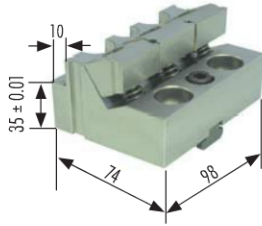

F-Tool clamping block B100

The clamping block B100 is hardened and made of rust resistant material. The clamping block is flexibly applicable and can be applied directly on every T-slot machine table. The shoulder of the clamping block serves as a fixed stop as well.

Article no.	Article	Quantity	Weight	Code
FT 01961	FTool clamping block B100/25 L74	1 piece	2.31 kg	P

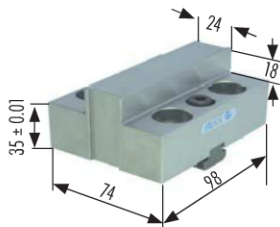

F-Tool double stopper B100

The double stopper B100 can be applied on T-slot machine tables together with the clamping block B100.

Article no.	Article	Quantity	Weight	Code
FT 01962	FTool double stopper B100/35 L24/74	1 piece	2.20 kg	P



F-Tool double stopper B100

The parallel support set is suitable for the flat clamping of work pieces, but can as well be used for parallel clamping. The bails avoid the drop-out while turning or while cleaning the vises with compressed air.

Article no.	Article	Quantity	Weight	Code
FT 01963	FTool parallel cales set 14 mm B100	Set of 2 pieces	0.22 kg	P

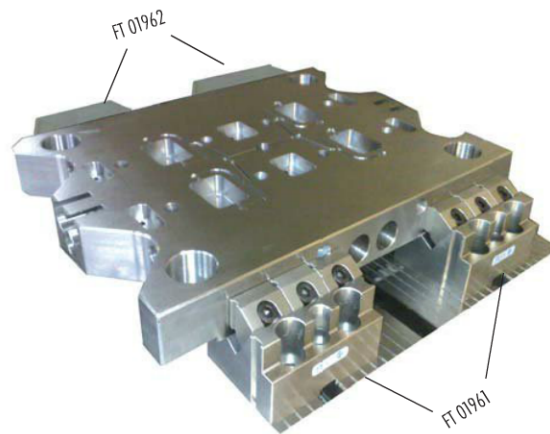

with multifunctional applications

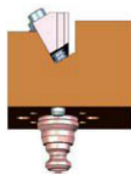

The PIN BrassClamp FT 01807 and the PIN MultiClamp FT 01809 are prepared for the following clamping possibilities:

- A. Hole grid for socket head bolt M8 distance 40 mm for T-slot pallet and grid plate
- B. PIN system with PIN index
- C. 3R adapter plate
- D. The PIN index drill holes can also be used to disconnect $2 \times \varnothing 8 \text{ H7} / 60 \text{ mm}$

The PIN BrassClamp FT 01808 and the PIN MultiClamp FT 01810 are equipped with ITS 50 centering plates.

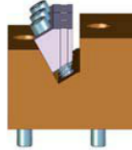
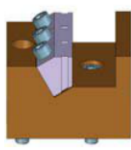
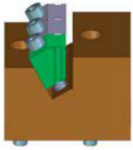

All PIN BrassClamps and PIN MultiClamps are equipped with three pull-down clamping elements (A) as standard, each of which can be used individually. The pull-down elements are lifted with compression springs (C). The clamping travel (B) is 3 mm. The BrassClamp can be individually extended to a clamping range of 28 mm (D). If required, it can be adjusted to the shape of a specific work piece.

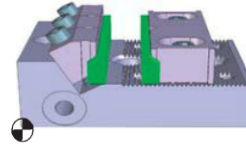
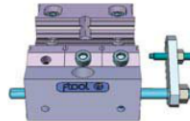
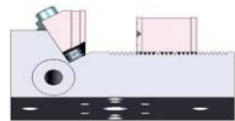
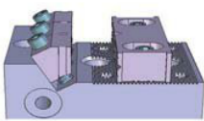

The F-Tool PIN MultiClamp has been designed for multiple applications. All relevant dimensions relate to the mounting-side (B) and the front-side (A) of the MultiClamp. This enables the combined assembly of multiple MultiClamps in reference position and also means that recurring pieces can be clamped in a defined grid. The production tolerance of the relevant dimensions is $\pm 0.01 \text{ mm}$. As an option, the MultiClamps can be equipped with the fixed stop FT 01812 (C) or the PIN parallel set 16 mm FT 01813 (D) (example MultiClamp105).

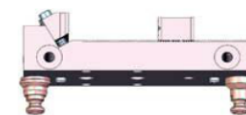
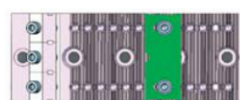

The stop jaw (A) can be used on both sides, the smooth, polished side (B) or following rotation through 180° , the horizontally and vertically polished prism-side (C).

The relocation matrix (D) measures 2 mm.

E. Mounting example PIN MultiClamp 181 with a RefPIN set FT 01816

F. Mounting example PIN MultiClamp 181 with a RefPIN twinset FT 01816

G. The hole grid at the MultiClamp 105 and 181 is 40 mm.

H. The mounting holes are prepared from above for socket head bolts M8 x 25 mm and from below with threaded hole for M10.

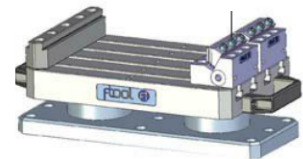
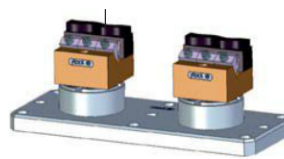
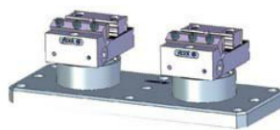

The F-Tool PIN clamping concept offers you a multiplicity of possibilities. The PIN ZeroPoint centering system has been developed without compromise for price-oriented, modern production.

The F-Tool pull-down vises are specifically manufactured for modern and economic production. This flexible concept offers a great number of clamping and application options. These vises are of a particular use in the flexible, multiple collection of pallets in automation processes. And automation will become even more attractive due to the reasonable prices of these F-Tool clamping devices.

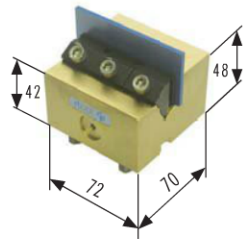

F-Tool PIN BrassClamp

The F-Tool PIN BrassClamp is a brass retainer with hardened, corrosion-resistant pull-down jaws. If necessary, the stop surface on the holder can be milled to approx. 28 mm. The BrassClamp is supplied as standard with 3 clamping jaws with a clamping range of 0-3 mm. The BrassClamp is suited for use as an electrode (in particular graphite) retainer. However, it can also be used as precision parts clamp, because the brass jaw can be enlarged precisely.

B40 = prepared for PIN system, 3R adapter plate, T-slides and grid plate 40 mm/M8. Delivered with screws
 ITS 50 = equipped with ITS centering plates 50 / EWIS preparation. Delivered with ITS chucking spigot F/A

Article no.	Article	Quantity	Weight	Code
FT 01807	FTool PIN BrassClamp 72 x 72 mm B40	1 piece	1.85 kg	P
FT 01808	FTool PIN BrassClamp 72 x 72mm ITS50	1 piece	2.00 kg	P

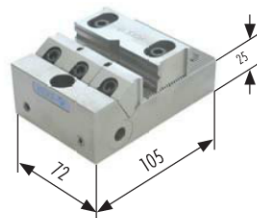

F-Tool MultiClamp 105

The F-Tool MultiClamp is a precision pull-down clamp with adjustable, hardened pull-down and stop jaws. It is manufactured from hardened, corrosion-resistant steel. The stop jaw can be adjusted in the tooth grid every 2 mm. The support surface has a tolerance of +/- 0.01 mm. Suited as multiple-spanner on T-slot pallet, ITS/UPC pallets, square block etc.

The clamping range total is 48 mm.
 The clamping range of the flexible jaws is 3 mm H 25 mm.

B40 = prepared for PIN system, 3R adapter plate, T-slides and grid plate 40 mm/M8. Delivered with screws
 ITS 50 = equipped with ITS centering plates 50 / EWIS preparation. Delivered with ITS chucking spigot F/A

Article no.	Article	Quantity	Weight	Code
FT 01809	FTool PIN MultiClamp 105 x 72 mm B40, corrosion-resistant	1 piece	1.85 kg	P
FT 01810	FTool PIN MultiClamp 105 x 72 mm ITS50, corrosion-resistant	1 piece	1.95 kg	P

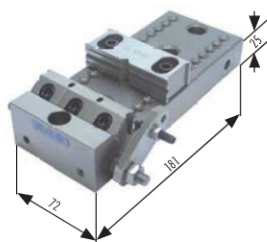
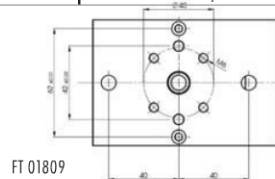

F-Tool MultiClamp 181

The F-Tool MultiClamp is a precision pull-down clamp with adjustable, hardened pull-down and stop jaws. It is manufactured from hardened, corrosion-resistant steel.

Hole grid 40 mm. Suited as T-slot pallet, grid plate, on ITS square block or pallet 148 mm.

The clamping range total is 124 mm.
 The clamping range of the flexible jaws is 3 mm.

Article no.	Article	Quantity	Weight	Code
FT 01811	FTool PIN MultiClamp 181 x 72 mm B40, corrosion-resistant	1 piece	2.86 kg	P

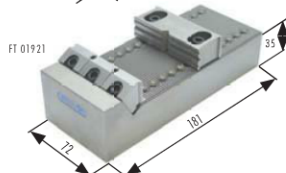
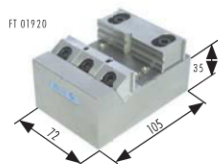
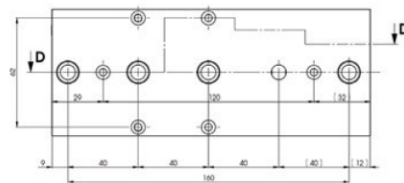

F-Tool MultiClamp ERP148

The MultiClamps 105/35 and 181/35 are predestinated to assemble together with the EROWA Standard pallets with hole pattern 4 x M8 Ø 37 mm respective 4 x M8 110 x 50 mm. The table height is 35 mm +/- 0.01 mm. The clamping range is identical to the FT 01809 respective FT 01811.

Article no.	Article	Quantity	Weight	Code
FT 01920	MultiClamp 105/35 for ERP148	1 piece	2.51 kg	P
FT 01921	MultiClamp 181/35 for ERP148	1 piece	4.04 kg	P

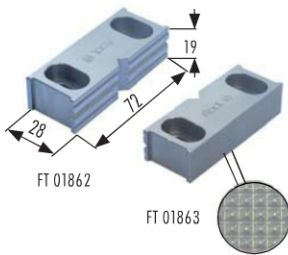

Prism reversible jaw height 19

The F-Tool prism reversible jaws 19 mm are the standard sizes and can be assembled in the grid of 2 mm on the MultiClamp 105 and 181. According to the purpose of use, the surface-grounded, the prism side or for blanks, the grip-prism reversible jaw is appropriate.

Article no.	Article	Quantity	Weight	Code
FT 01862	Precisions-prism reversible jaw S-72h19	1 piece	0.28 kg	P
FT 01863	Grip-prism reversible jaw SG-72h19	1 piece	0.28 kg	P
FT 02011	Fix stop jaw soft alu 38 x 72 x h19 mm	Set of 5 pieces	0.72 kg	P

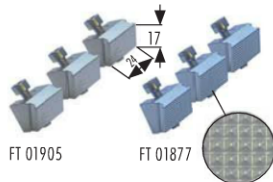

Clamping jaws height 19

The F-Tool clamping jaws have a clamping range of 3 mm. They can be used on the multiclamps 105 and 181, as well as on the clamping blocks B72. The lateral slot allows the attachment of supports FT 01868 or extension jaws FT 01887. Max. clamping range 4 - 5 kN/clamping jaw

Article no.	Article	Quantity	Weight	Code
FT 01877	Grip-clamping jaw set SCG24-h19	Set of 3 pieces	0.20 kg	P
FT 01905	Clamping jaw set SC24-h19	Set of 3 pieces	0.20 kg	P

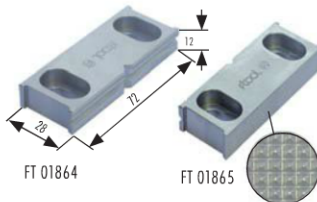

Prism reversible jaws height 12

The prism reversible jaws 12 mm are suitable for the clamping of rather flat work pieces. The function is otherwise identical with the standard prism reversible jaws 19 mm. They can be used on the multiclamps 105 and 181.

Article no.	Article	Quantity	Weight	Code
FT 01864	Flat-prism reversible jaw F-72h12	1 piece	0.20 kg	P
FT 01865	Flat-grip reversible jaw FG-72-h12	1 piece	0.20 kg	P

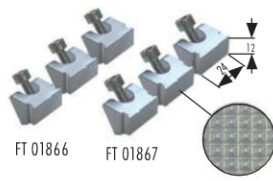

Flat-clamping jaws height 12

The flat-clamping jaws are suitable for the use with the prism reversible jaw 12 mm. Max. clamping range 4 - 5 kN/Clamping jaw. Applicable on multiclamps 105 and 181 as well as on the clamping blocks B72.

Article no.	Article	Quantity	Weight	Code
FT 01866	Flat-clamping jaw set FC24-h12	Set of 3 pieces	0.16 kg	P
FT 01867	Flat-grip-clamping jaw set FCG24-h12	Set of 3 pieces	0.16 kg	P

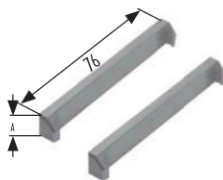

F-Tool PIN parallel support set

The parallel support set is suitable for the flat clamping of work pieces, but can as well be used for parallel clamping. The baits avoid the drop-out while turning or while cleaning the vises with compressed air.

Article no.	Article	Quantity	Weight	Code
FT 01888	FTool PIN parallel support set 10 mm (A = 10 mm)	Set of 2 pieces	0.10 kg	P

Combination examples:

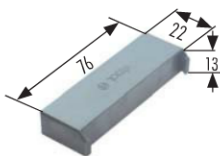
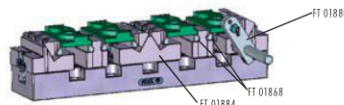

F-Tool extension jaw

The extension jaw bridges the level of the clamping blocks to the parallel clamping of high work pieces.

Article no.	Article	Quantity	Weight	Code
FT 01887	FTool extension jaw 22h13	1 piece	0.20 kg	P
FT 02012	Mobil jaw soft alu MC 22 x 72 x h19 mm	Set of 5 pieces	0.50 kg	P

Combination examples:

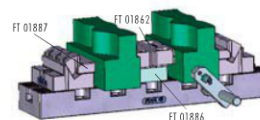
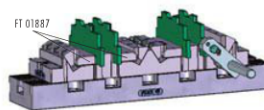

- For milling, grinding, EDM sinking and EDM wire-cutting
- Great flexibility with few clamping elements
- Accurate production, rust-resistant

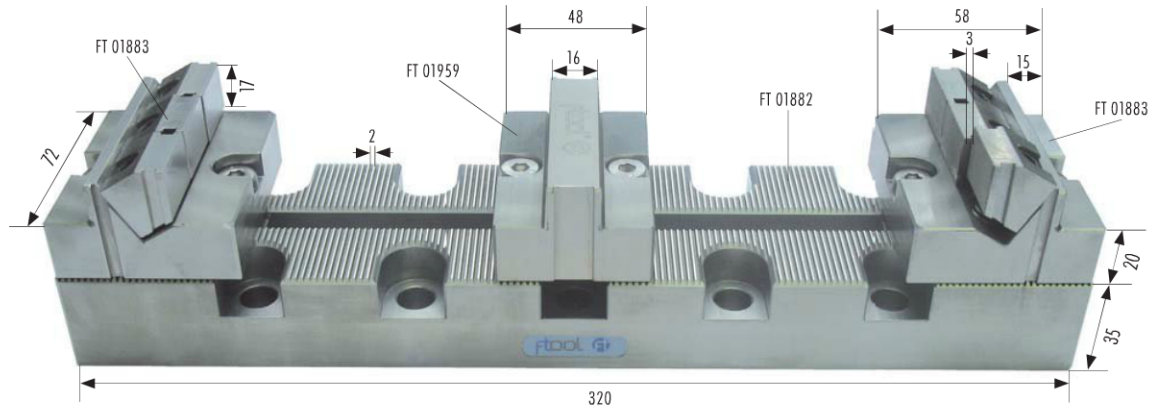

F-Tool MC railer view assembling side

- The MC railer can be assembled directly on UPC 320 pallets or other breadboards with 50 mm hole centre distance.
- Likewise applicable to EDM wire-cutting thanks to rustless construction and vertical clamping with two MultiClamp IF FT 01878.
- Equipped with TwinSet, connected firmly and precise in the PIN ZeroPoint centering system MB 160.

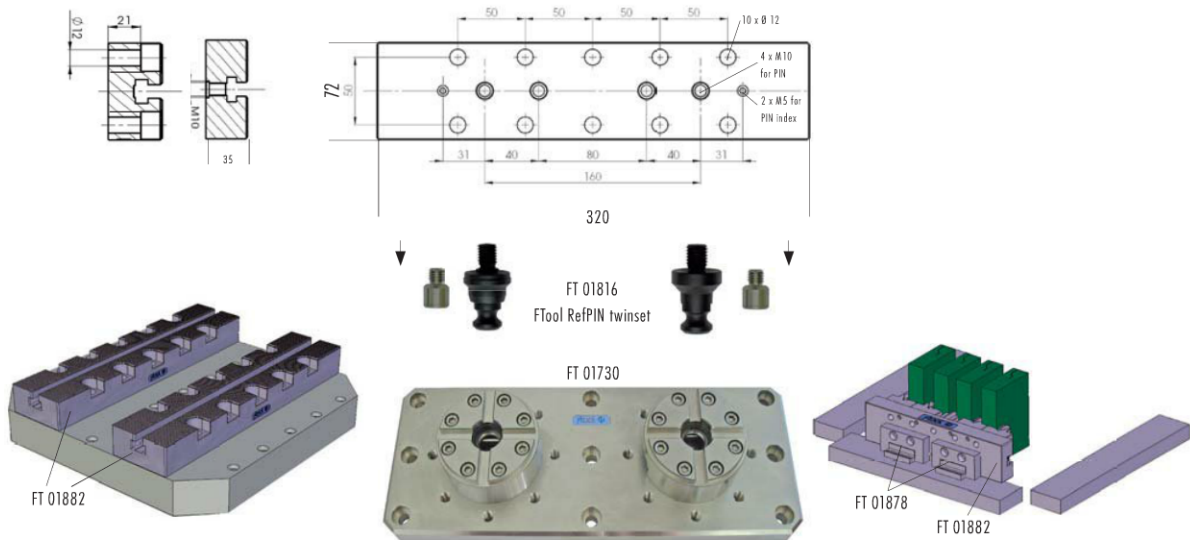

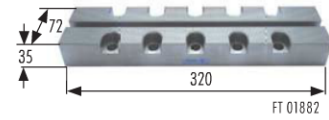

FT 01882



FT 02052



F-Tool MC railer 320 B72

The multiclamp railer 320 B72 is made of rust-resistant material, hardened and precision ground.

Dimension: 320 x 72 x 35 mm, tooth grid 2 mm, hole grid \emptyset 12 x 50 mm.

The railer fits on the pallet with hole grid 50 mm.

Article no.	Article	Quantity	Weight	Code
FT 01882	FTool MC railer 320 B72	1 piece	5.40 kg	P
FT 02052	FTool MC railer 400 B72	1 piece	6.90 Kg	P

Universal alu pallet MTS 200/250

The alu pallet MTS 200/250 is for the collet of the railer FT 01882 and FT 02055. The pallet is processed with hole grid for the MTS chucking spigot set 2 ER 041460 with distance 200/250. Delivered without chucking spigots.

Article no.	Article	Quantity	Weight	Code
FT 02055	Universal alu pallet 400 x 200 x 35 mm with handles	1 piece	7.99 Kg	P



FT 02055 + FT 01882 +
FT 01959 + FT 01883



FT 02055 + FT 02052 +
FT 01959 + FT 01883

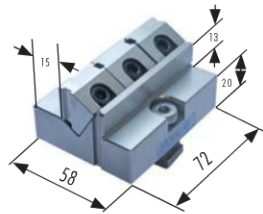

F-Tool MC clamping block B72/20 L58

The clamping block with fixed stop fits the railer 320 B72 and 400 B72. Made of rust resistant material, hardened and ground. With the three clamping jaws a tension can be caused of 3.5 t. The clamping principle of the clamping jaws produces an optimal pull-down effect.

Article no.	Article	Quantity	Weight	Code
FT 01883	FTool MC clamping block B72/20 L58	1 piece	0.88 kg	P

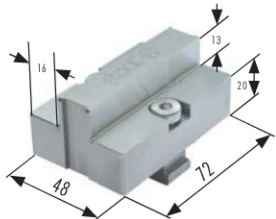

F-Tool MC stopper beam B72/20 L48/16

The MC stopper beam B72 fits the railer 320 B72 and 400 B72. The MC stopper beam is made of rust resistant material, hardened and precision ground.

Article no.	Article	Quantity	Weight	Code
FT 01959	FTool MC stopper beam B72/20 L48/16	1 piece	0.70 kg	P

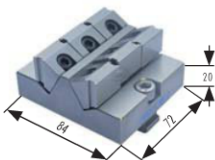

F-Tool double clamping block

The F-Tool double clamping block is suitable for the multiple clamping on the MC railer B72.

Article no.	Article	Quantity	Weight	Code
FT 01884	FTool MC double clamping block B72/20 L84	1 piece	1.35 kg	P

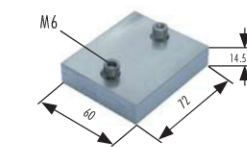

F-Tool MC stopper beam base B20 / 40

On these MC stopper beam bases, aluminium jaws or the F-Tool prism reversible jaws can be assembled.

Article no.	Article	Quantity	Weight	Code
FT 01886	FTool MC stopper beam base B20 / 40	1 piece	0.48 kg	P
FT 01888	FTool alu jaw 72 x 60 x 14.5 mm	1 piece	0.24 kg	P

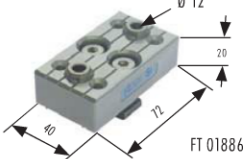

FT 01886

Combination examples:

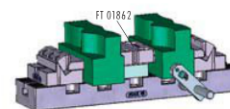
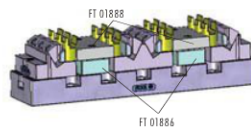



F-Tool MC stopper beam

The F-Tool MC stopper beam B72 h60 fits on the MC railer 320 B72 and 400 B72.

Article no.	Article	Quantity	Weight	Code
FT 02035	FTool stopper beam B72 x 56 x h60 mm	1 Stück		P



FTool Clamping Block B72 h60

The F-Tool clamping block B72 h60 fits on the MC railer 320 B72 and 400 B72.

Article no.	Article	Quantity	Weight	Code
FT 02036	FTool clamping block B72 h60 with large clamping jaw	1 piece	1.77	P



F-Tool support set B72 h25

The F-Tool support set B72 h25 fits on the MC stopper beam FT 02035 and the clamping block FT 02036.

Article no.	Article	Quantity	Weight	Code
FT 02038	FTool support set B72 h25	Set of 2 pieces		P



F-Tool clamping jaw 72 mm

It is possible to use the F-Tool clamping jaw 72 mm in place of the 3 pull-down clamping elements.

Article no.	Article	Quantity	Weight	Code
FT 01814	FTool clamping jaw 72 mm, corrosion-resistant	1 piece	0.20 kg	P

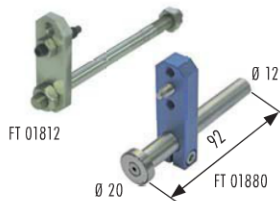

F-Tool fixed stop

A stop element for the F-Tool MultiClamps and the F-Tool clamping block.

Article no.	Article	Quantity	Weight	Code
FT 01812	FTool fixed stop complete	1 piece	0.15 kg	P
FT 01880	Adjustable magnetic base-stop	1 piece	0.20 kg	P